

**EXISTING BUILDING**

**NEW ADDITION**

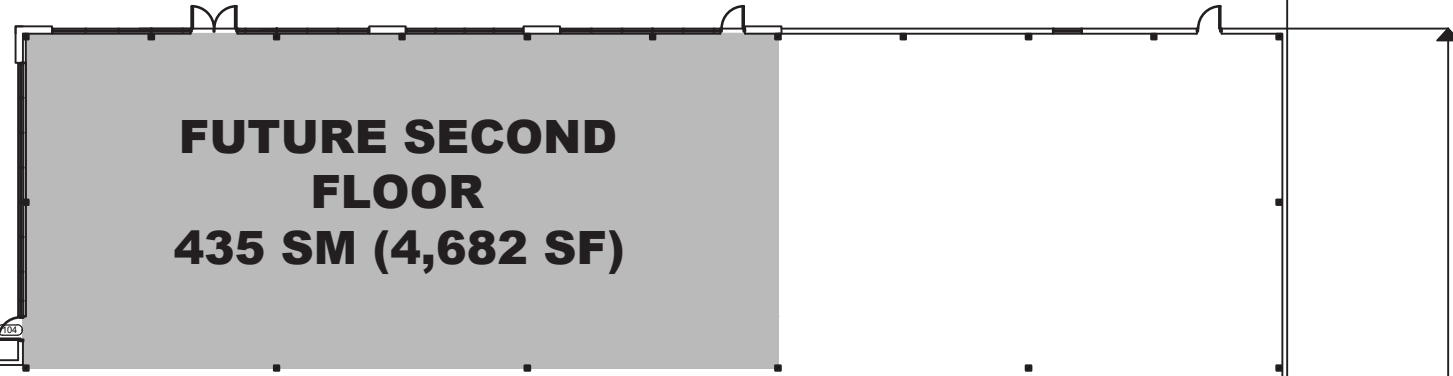
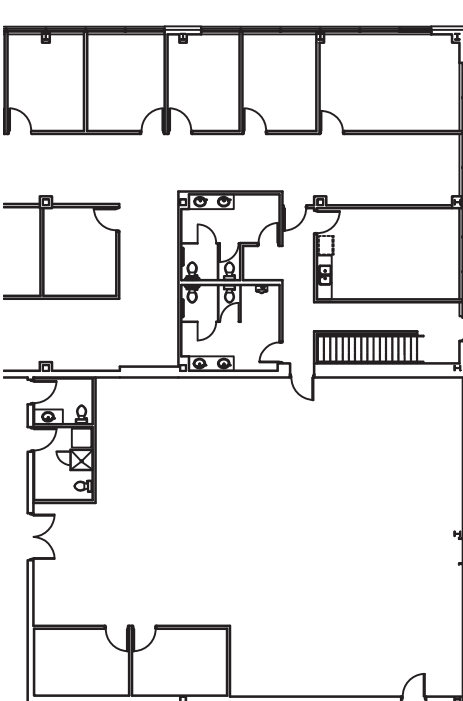

**FUTURE SECOND FLOOR**  
**435 SM (4,682 SF)**

*BLDG. AREA = 44,325 SF*  
*FUTURE SEC. FLR. = 4,682 SF*  
*TOTAL AREA = 48,953 SF*  
*Typ. Bay Size = 34' x 45'*

**EXISTING BUILDING**

**BUILDING B ADDITION**  
**4,118 SM**  
**(44,325 SF)**

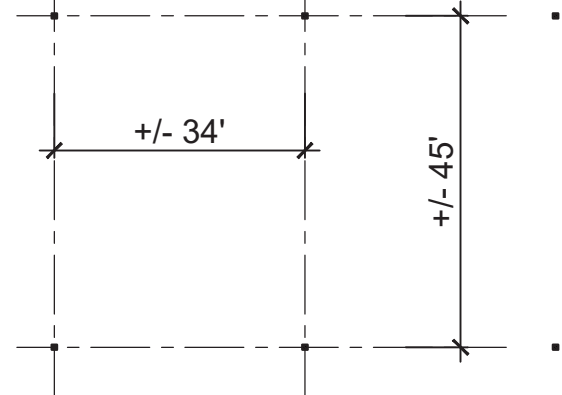

**NEW ADDITION**

